

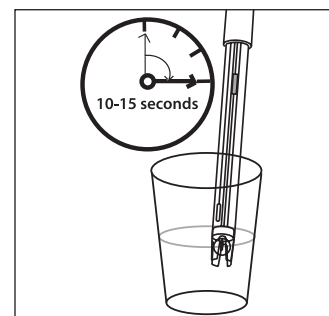

GLASS BODY, SEALED AND REFILLABLE PH ELECTRODES, PH HALF CELLS

PRODUCT INSTRUCTION MANUAL

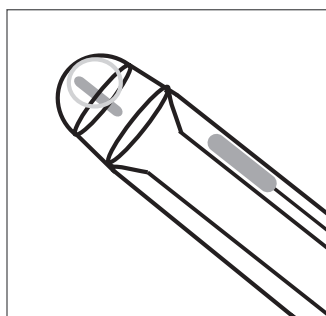
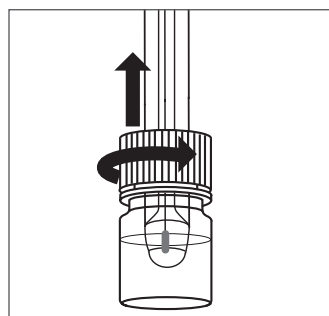
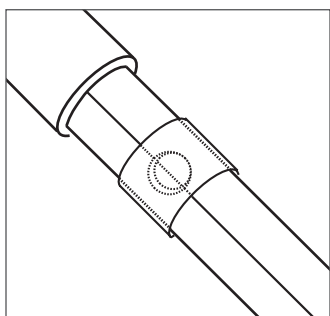
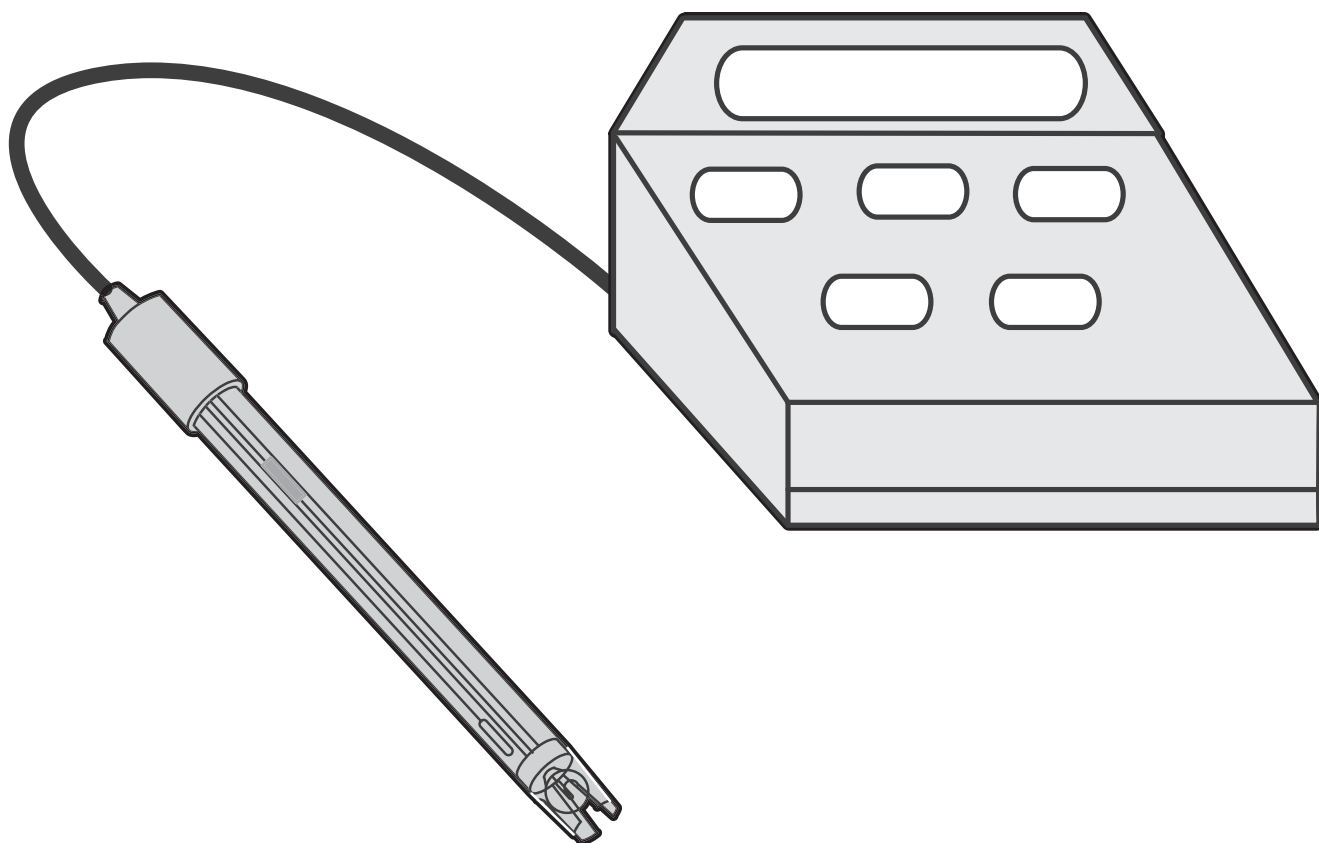

DESIGNED AND ASSEMBLED IN CALIFORNIA, USA

11751 MARKON DRIVE • GARDEN GROVE, CA 92841 • 714.895.4344 • WWW.SENSOREX.COM

SECTION 1.0 INTRODUCTION

Sensorex glass body combination electrodes are ruggedly made and easy to use. Because the pH-responsive bulb is relatively thin care should be taken to avoid breaking the bulb. Also, care should be taken so that the bulb does not become scratched or broken. The suggestions in this sheet are intended to help avoid these problems.

The sealed reference design eliminates the need to add filling solution and minimizes reference dryout. Refillable electrodes require re-filling with KCl solution when the liquid level is about 1" below the re-fill hole. To do this, slide the protective outer sleeve up to expose the filling hole and fill the electrode to the hole level with KCl (potassium chloride) solution. Slide the sleeve down to cover the hole (FIG. 1)

HELPFUL OPERATING TECHNIQUES

1. The electrode is shipped in a plastic bottle containing a solution of 4 buffer and potassium chloride. The electrode should remain in the bottle until it is used. Remove electrode as shown in FIG.2 If the electrode is used infrequently the bottle and its solution should be saved and the electrode stored in it (See Electrode Storage Section).
2. During shipment the air bubble in the electrode's stem may move into the bulb area (FIG. 3). If bubbles are seen in the bulb area, hold the electrode by its top cap and shake downwards as is done with a clinical thermometer (FIG 3, next page).
3. Although vigorous stirring more rapidly brings a sample, buffer or rinse solution to the pH bulb's surface more quickly and will improve speed of response, care must be taken to keep the bulb from striking a surface.. The electrode should be mounted in the holder provided with the pH meter and, if possible, the holder's rod marked with tape to prevent the electrode from being too deeply immersed in the beaker. The electrode never should be used as a stirring rod.

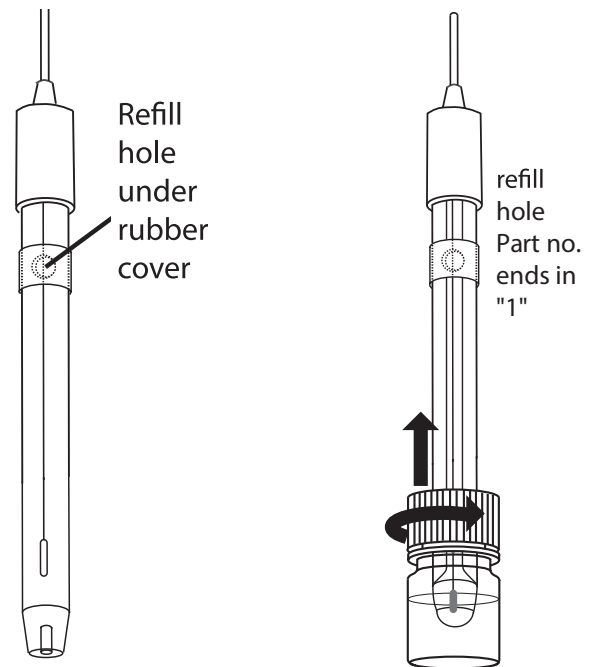

Fig. 1

Fig. 2

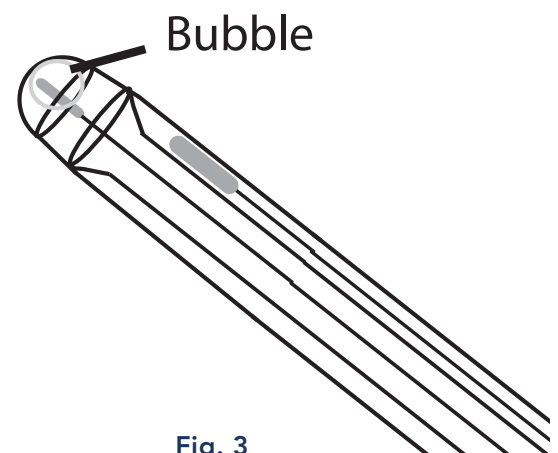

Fig. 3

4. After exposure to a sample, buffer or rinse solution, carryover can be minimized by blotting –never by wiping—the electrode with a non-abrasive paper or cloth towel.
5. As a rinse solution, use a part of the next sample or buffer that is to be measured. This action also will minimize contamination from carryover.
6. When calibrating, use a buffer close in value to that expected from the sample. This action will minimize span errors.
7. Keep buffers and samples at the same temperature. This action will eliminate the need to correct values for temperature effects.
8. pH readings stabilize faster in some solutions than others; allow time for the reading to stabilize. In general, buffers provide stable readings in several seconds (tris buffers take somewhat longer).
9. Keep in mind that all pH electrodes age with time. Aging is characterized by shortened span and slower speed of response. If the pH meter has a manual or microprocessor slope (span) control, the control can be adjusted to compensate for electrode span errors (but will not affect the speed of response). Aging is best detected by calibrating the electrode in, for example, 7 buffer, then rinsing and placing the electrode in 4 buffer. As a rule, if the span is 10% or more in error (a reading of 4.3 or higher for this example) the electrode should be cleaned and retested (see the Electrode Cleaning section) or reconditioned (see the Reconditioning section). If performance is not restored the electrode should be replaced.

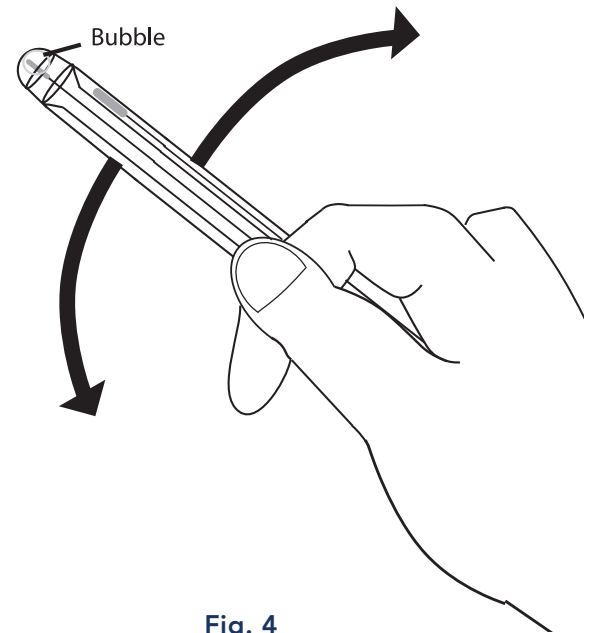

Fig. 4

Parts covered by this product instruction sheet include: pH1400, pH2400, SG700RD, SG201CD, SG300C, SG301C, SG360CD, SG700C, SG701C, SG900C, SG901C, SG1050CD, SG200G,

SECTION 2.0 CALIBRATION PROCEDURE

As a rule, follow the procedures recommended by the pH Meter manufacturer keeping in mind the Helpful Operating Techniques given above. The frequency of calibration is a function of the electrode, the pH meter and the solutions the electrode is exposed to. The electrode

1. Remove the electrode from its soaker bottle and save the bottle.
2. Rinse the electrode with deionized water from a squirt bottle or carefully stir the electrode in a beaker of rinse solution.
3. Remove residual drops of solution from the electrode by blotting with a non-abrasive paper or cloth.
4. Insert the electrode in the buffer or sample and stir gently.
5. Allow the reading to stabilize and then adjust the meter (if calibrating) or take the reading (if making a measurement).
6. Repeat these steps for each sample or buffer determination.

NOTE: if the electrode's span is to be checked (as should be done from time to time) repeat steps 2 through 4 with a second buffer, allow the reading to stabilize and adjust the span (slope) control or compare the buffer readings per step 9 above.

7. Between readings place the electrode in a beaker containing about 2 cm (1 inch) of, preferably, pH 4 buffer or distilled water.

and meter should always be calibrated together with the calibration frequency determined by experience. Use two buffers, for example 7 & 4 or 7 & 10 (FIG. 5). Use the following step-wise procedure for both calibration in buffers and for sample measurements.

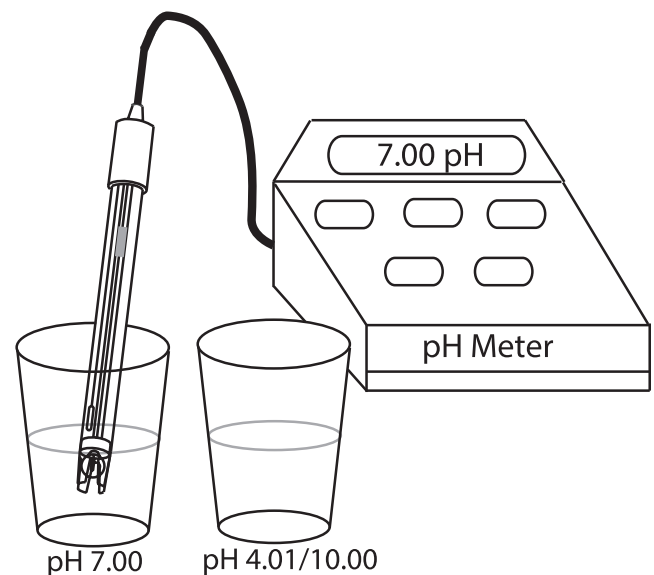

Fig. 5

SECTION 3.0 ELECTRODE STORAGE

When pH readings are made infrequently, for example, several days or weeks apart, the electrode can be stored simply by replacing it in its soaker bottle. First, slide the cap onto the electrode, then the o-ring, then insert the

electrode into the bottle and firmly tighten the cap. If the solution in the soaker bottle is missing, fill the bottle with pH 4 buffer.

SECTION 4.0 CLEANING PROCEDURE

Coatings that coat the reference junction can cause reading errors and coatings must be removed if accurate results are to be obtained. We first suggest a rinse in 5% HCl for 5 minutes. Some coatings may not dissolve in HCl and so you can try a liquid detergent. If proteins are in the sample, Terg-A-Zyme®, a powdered detergent that contains enzymes that breakdown proteins, is recommended. Alcohol may be used for stubborn organic deposits but do not soak electrode in it. Do not use a brush or abrasive cleaner. (FIG. 6)

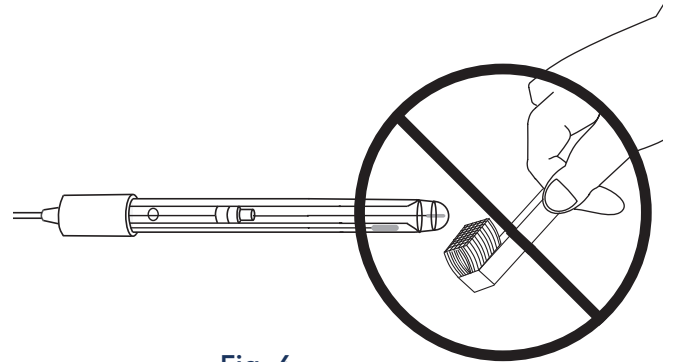

Fig. 6

SECTION 5.0 ELECTRODE RECONDITIONING

When reconditioning is required due to electrode aging (see Helpful Operating Techniques, Part 9), the following chemical treatments can be tried. They are presented in the order of the severity of their attack on the pH glass and may not improve (and in some cases actually further deteriorate) electrode performance. (FIG.7) NOTE: Use proper precautions when handling these hazardous chemicals. Ammonium bifluoride and HF (hydrofluoric acid) are extremely hazardous and should only be used by qualified personnel.

1. Immerse the electrode tip in 0.1N HCl for 15 seconds, rinse in tap water and then immerse tip in 0.1N NaOH for 15 seconds and rinse in tap water. Repeat this

sequence three times and then recheck electrode performance. If performance has not been restored, try Step 2.

2. Immerse the tip in a 20% solution of NH_4F (ammonium bifluoride) for 2 or 3 minutes, rinse in tap water and recheck performance. If performance has not been restored, try Step 3.
3. Immerse electrode tip in 5% HF for 10 to 15 seconds, rinse well in tap water, quickly rinse in 5N HCl, rinse well in tap water and recheck performance. If performance has not been restored it is time to get another glass body combination pH electrode.

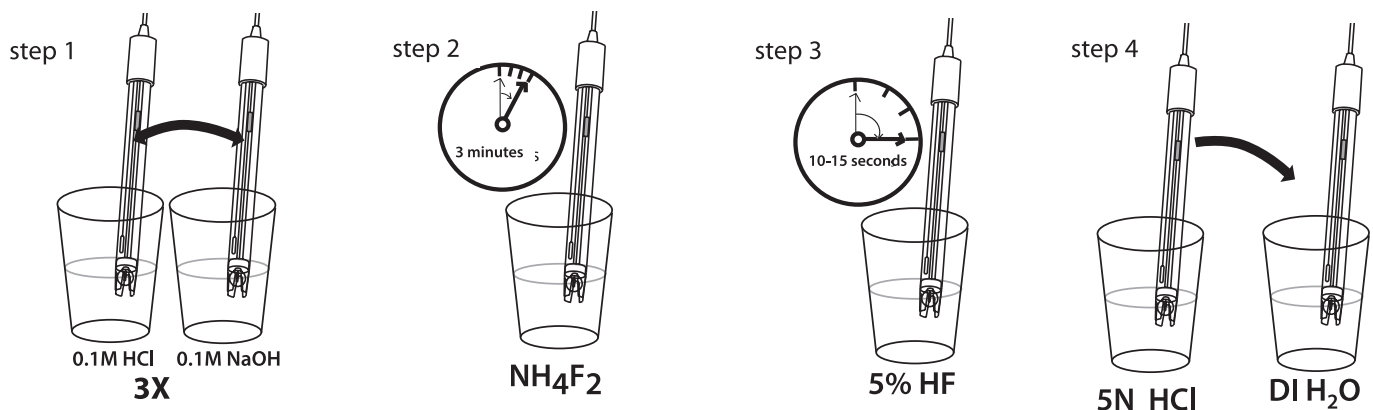

Fig 7



DESIGNED AND ASSEMBLED IN CALIFORNIA, USA

11751 MARKON DRIVE • GARDEN GROVE, CA 92841 • 714.895.4344 • WWW.SENSOREX.COM

© Sensorex Corporation. All rights reserved. In the interest of improving and updating its equipment, Sensorex reserves the right to alter specifications to equipment at any time.