

Polymer Body, Sealed Combination ORP/Reference Electrodes

Product Instructions

While these instructions are specifically intended for users of Combination REDOX Electrodes, they also can be applied to the use of separate REDOX and Reference Electrodes. Although REDOX Electrodes do not have the fragile glass bulb that is found in pH Electrodes, care should still be taken to prevent their ends from striking hard surfaces and to prevent their platinum sensing surfaces from becoming scratched. The suggestions and procedures in these instructions are intended to help users avoid these problems.

Section 1.0 Helpful Operating Tips

1. As shipped, the ORP electrode is shipped in a bottle of soaking solution. To remove the electrode from the soaker bottle, rotate cap counter-clockwise and remove electrode by pulling upward (SEE FIG 1). Save bottle and cap for later if you intend to store the electrode for a few days or more.
2. Although vigorous stirring in the laboratory or high velocities in flowing systems brings a sample, calibration standard or rinse solution to reference junction faster and improves speed of response, care must be taken to keep from striking another surface or being hit by a stirring rod, etc. In the laboratory, the electrode should be mounted on the holder that comes with the meter and, if possible, the holder's rod marked with tape to prevent the electrode from being lowered so far that it strikes the bottom of the container or a stirring rod (SEE FIG 2).
3. After exposure to a sample, calibrating standard or rinse solution, minimize carryover by a snap action as shown in FIG 3, shaking of the electrode to remove residual drops of solution. Alternately, the electrode can be wiped dry with an absorbent paper or cloth towel.
4. As a rinse solution, use a part of the next solution to which the electrode will be exposed. This action will also minimize contamination from carryover.
5. When calibrating, keep the temperature of the calibrating standard within a few degrees Celsius of some value that is conveniently maintained at your location. Doing this will minimize changes in readings due to temperature changes.

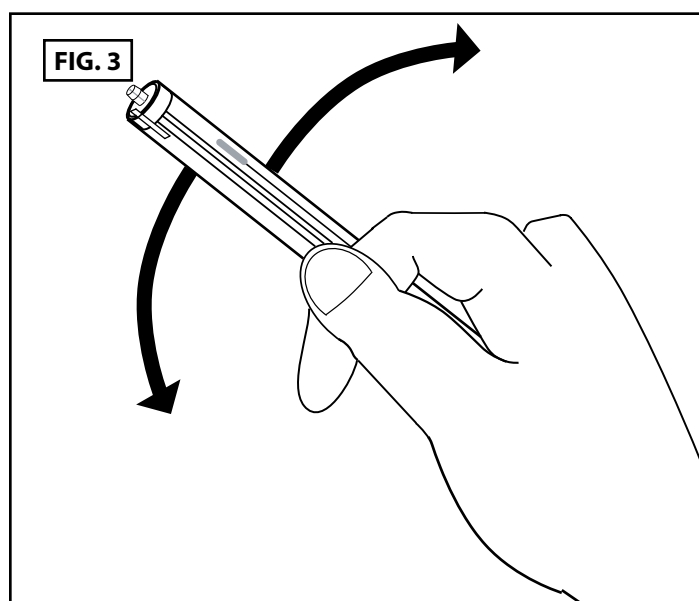
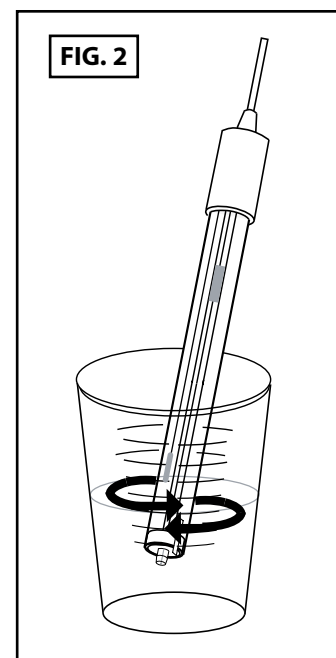
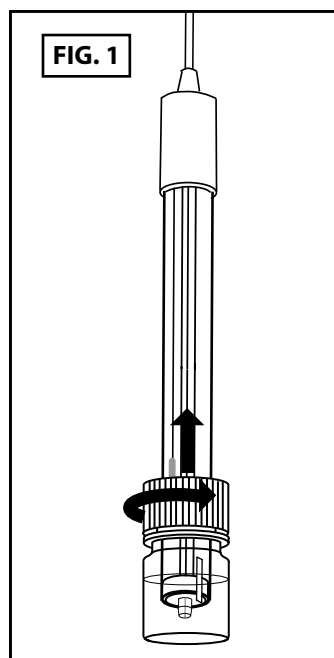

Parts covered by this product data sheet include:
 500C/CD-ORP, S510C/CD-ORP, S222C/CD-ORP,
 S550C/CD-ORP, S450C/CD-ORP, S350CD-ORP, S500C/CD-ORP-Au,
 S550C/CD-ORP-Au

Section 1.0 Helpful Operating Tips (Cont.)

- The type of Reference Electrode used will affect the millivolt readings of both samples and calibration standards. The two commonly used Reference Electrode types differ by having internals made of silver/silver chloride (Ag/AgCl) or internals made of calomel. Both Combination and Separate Reference Electrodes that are accompanied by these instructions have Ag/AgCl internals and have 3.5 M KCl gels. This type of electrode will give a reading of about +40 mV as compared to Reference Electrodes with calomel internals and saturated KCl solutions.
- Depending on the composition of the REDOX Calibration Solution, with time the solution may be oxidized or reduced and this will change its reading. In general, then, REDOX Calibration Solutions cannot be relied on for long term—many months or years—stability (the user should refer to the solution's manufacturer for recommendations regarding solution stability).
- When REDOX potentials are used to continuously monitor the concentration of the single chemical which is easily determined by other means (in the above example, a colorimetric test kit could be used), a REDOX Calibration Standard usually is not needed. The grab sample calibration method described below can be used in such instances.

Section 2.0 Calibration Procedure

As a general rule, follow the procedures recommended by the REDOX Meter manufacturer keeping in mind the Helpful Operating Techniques given above. The frequency of calibration is a function of both the electrode and the meter. They should be calibrated together with the calibration frequency determined by experience. The following step-wise procedure has been found useful:

LABORATORY PROCEDURE

- Remove the electrode from the soaker bottle by rotating cap counter-clockwise and pulling electrode upward.
- Rinse the electrode with de-ionized or tap water by carefully stirring it in a beaker containing this rinse solution.
- Remove the electrode and wipe dry with a soft paper or cloth towel.
- Pour REDOX Calibration Standard solution into a small beaker to about a 3/8" (1cm) depth.
- Insert the electrode into the solution and gently stir taking care not to allow the end of the electrode to hit the beaker.
- Allow the reading to stabilize and compare it to the standard solution's value. Typically, the readings should agree within 10-15% of the solution's stated value (SEE FIG 4A).
- If the electrode is to be checked in a different standard solution, repeat steps 2 through 6.

FIG. 4

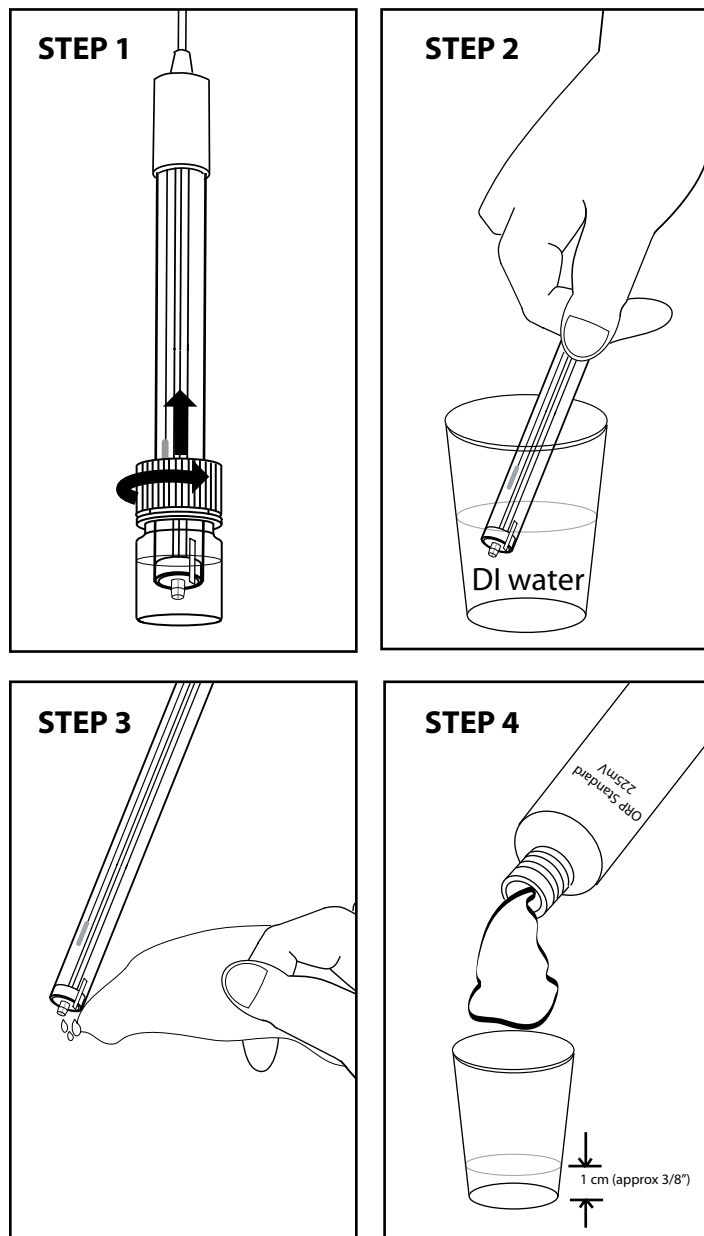

FIG. 4A

PLATINUM ORP ELECTRODE IN 7 BUFFER/QUINHYDRONE MIXTURE

Temperature	20C (68F)	25C (77F)	30C (86F)
Readings (mV)	89-107	83-101	76-94
Readings (pH)	5.20-5.50	5.30-5.60	5.42-5.72

PLATINUM ORP ELECTRODE IN 4 BUFFER/QUINHYDRONE MIXTURE

Temperature	20C (68F)	25C (77F)	30C (86F)
Readings (mV)	260-287	254-281	247-274
Readings (pH)	2.15-2.60	2.25-2.70	2.37-2.82

Section 2.0 Calibration Procedure (Cont.)

GRAB SAMPLE CALIBRATION

1. Collect a sample of solution the electrode is monitoring (take it from a place as close to the electrode as possible).
2. Just when the sample is collected, observe the meter reading and make a note of that value.
3. As quickly as possible, analyze the collected sample by an appropriate mean.
4. Now, if necessary, adjust the meter reading to reflect the difference between the analyzed sample and the meter reading when the sample was collected. For example, if the meter read 0.5ppm when the sample was collected and the analyzed sample value was 0.7 ppm, the meter would be adjusted + 0.2 ppm from whatever its present reading is.

Section 3.0 Electrode Storage

When readings are made infrequently, for example, several days or weeks apart, the electrode can be stored in the soaker bottle that it was shipped in. If you have poured out the soaking solution, simply refill the bottle with either pH 4.01 buffer or a mix 50:50 of water and distilled vinegar (do not use distilled water).

Section 4.0 Electrode Cleaning

Coating of the platinum sensing surface can prevent samples from reaching that surface and is a primary cause of erroneous readings. Materials that coat the reference junction can also cause reading errors and coatings must be removed if accurate results are to be obtained.

Soft coatings should be removed by use of a squirt bottle or by wiping with a soft cloth. Hard coatings or organic chemicals should be removed by use of appropriate chemicals such as 5% HCl. If a solvent is used, select one that does not damage the electrode materials that include epoxy, nylon, silicone rubber, platinum and glass. The platinum sensing surface is located in the end of the glass tube that extends from the electrode's body. It can be cleaned by gently polishing it with 600 grade wet silicon carbide paper but should only be done when chemical cleaning is not effective. Wet a piece of the paper with water and polish the electrode with a twisting and rocking action as shown in FIG 6 .

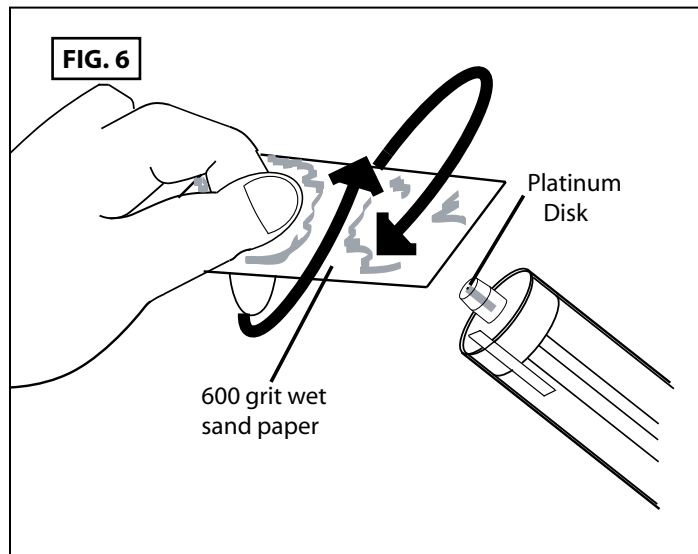
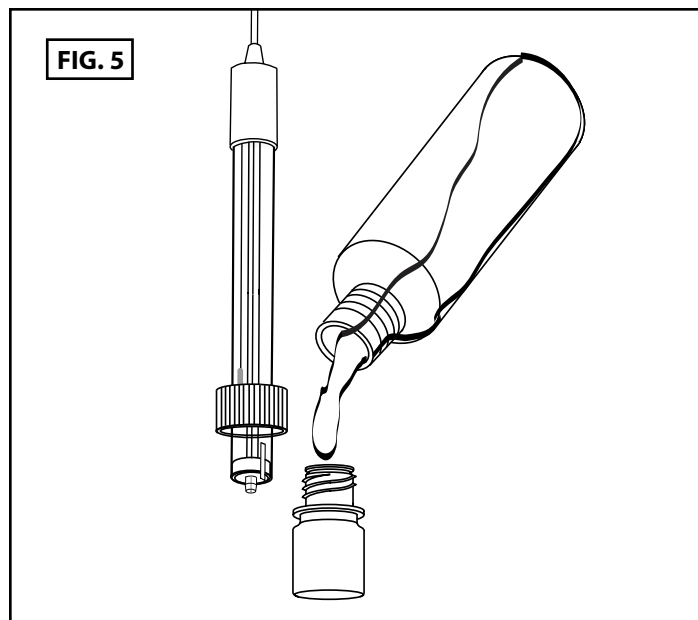

NOTE: After the platinum sensing surface has been cleaned, some period of time is required before it once again provides stable readings. In general, soak the electrode for 8 – 24 hours in the solution that the electrode usually monitors.

