

pHASE, Rapid Renew Junction, Glass Body Combination pH Electrodes

Product Instructions

INTRODUCTION

Sensorex pHASE Combination Electrodes with Rapid Renew Junctions are ruggedly made and easy to use. Glass Body models are supplied with ruggedized hemispherical pH glass surface. These electrodes feature Rapid-Renew Reference Junctions. Pressing down on the electrode's spring loaded Top Cap opens its ground glass sleeve-type reference junction allowing reference solution to flow out. This flow flushes out contaminants and, when the Top Cap is released, a new reference junction is formed.

SECTION 1.0 HELPFUL OPERATING TIPS

1. The electrode is shipped in a plastic bottle containing a solution of pH 4 buffer and potassium chloride. The electrode should remain in the bottle until it is used. If the electrode is used infrequently, the bottle and its solution should be saved and the electrode stored in it. (see Electrode Storage Section). Take out electrode by loosening plastic top on bottle counter-clockwise and pull electrode out. Slide cap and o-ring off electrode and save (SEE FIG 1).

2. During shipment the air bubble in the electrode's stem may move into the bulb area. If bubbles are seen in the bulb area, hold the electrode by its top cap and shake downward as is done with a clinical thermometer (SEE FIG 2)

3. Vigorously stir the electrode in the sample, buffer or rinse solution. This action will bring solution to the electrode's surface more quickly and improve speed of response.

4. After exposure to sample, buffer or rinse solution, shake the electrode with a snap motion to remove residual drops of solution. (SEE FIG 3 NEXT PAGE) This action will minimize contamination from carryover.

5. As a rinse solution, use a part of the next sample or buffer which is to be measured. This action will also minimize contamination from carryover.

6. When calibrating, use a buffer close in value to that expected from the sample. This action will minimize span errors.

7. Keep buffers and samples at the same temperature. This action will eliminate the need to correct values for temperature effects.

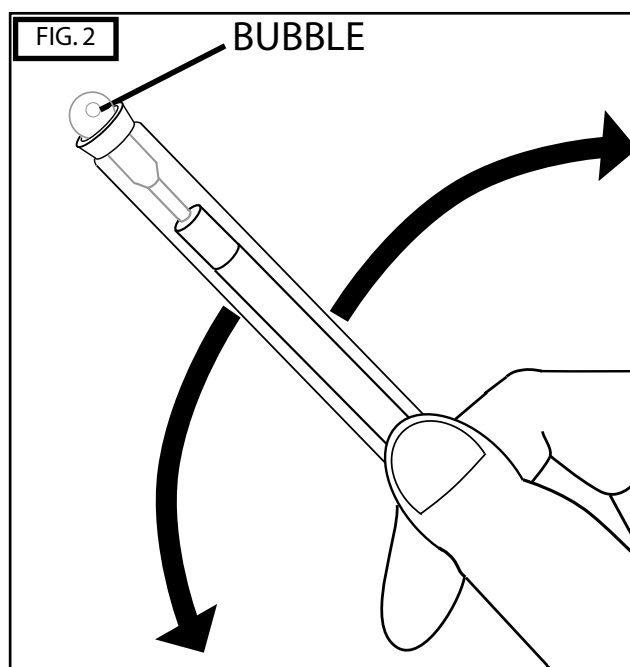
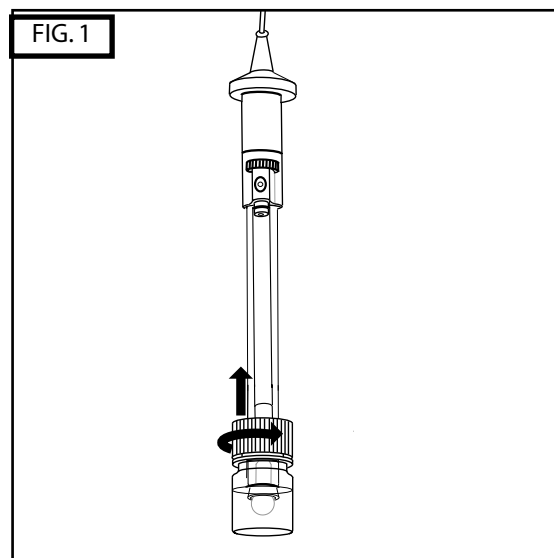

SECTION 1.0 HELPFUL OPERATING TIPS (CONT)

8. pH readings stabilize faster in some solutions than in others; allow time for reading to stabilize. In general, buffers provide stable readings in several seconds (tris buffers take somewhat longer) while samples usually take longer times.

9. Keep in mind that all pH electrodes age with time. Aging is characterized by shortened span (slope) and slower speed of response. If the meter has a manual or microprocessor slope control, the control can be adjusted to compensate for electrode span errors (but will not affect the speed of response). Aging is best detected by calibrating the electrode in, for example, pH 7 buffer, then rinsing and placing the electrode in pH 4 buffer. As a rule, if the span is 10% or more in error (a reading of 4.3 or higher for this example) the electrode should be cleaned and retested (see the Electrode Cleaning Section) or reconditioned (see Reconditioning Section). If performance is not restored the electrode should be replaced.

SECTION 2.0 CALIBRATION PROCEDURE

As a rule, follow the procedures recommended by the pH meter manufacturer keeping in mind the Helpful Operating Techniques given on page 1. The frequency of calibration is a function of the electrode, the pH meter and the solutions the electrode is exposed to. The electrode and meter should always be calibrated together with the calibration frequency determined by experience. Use two buffers, for example 7 & 4 or 7 & 10. (SEE FIG 4) Use the following step-wise procedure for both calibration in buffers and for sample measurements:

1. Remove the electrode from its soaker bottle and save the bottle.
2. Vigorously stir the electrode in a rinse solution.
3. Shake the electrode with a snap action to remove residual drops of solution.
4. Vigorously stir the electrode in the buffer or sample and allow the electrode to rest against the beaker's wall.
5. Allow the reading to stabilize and then take the reading.
6. Repeat these steps for each sample or buffer determination.

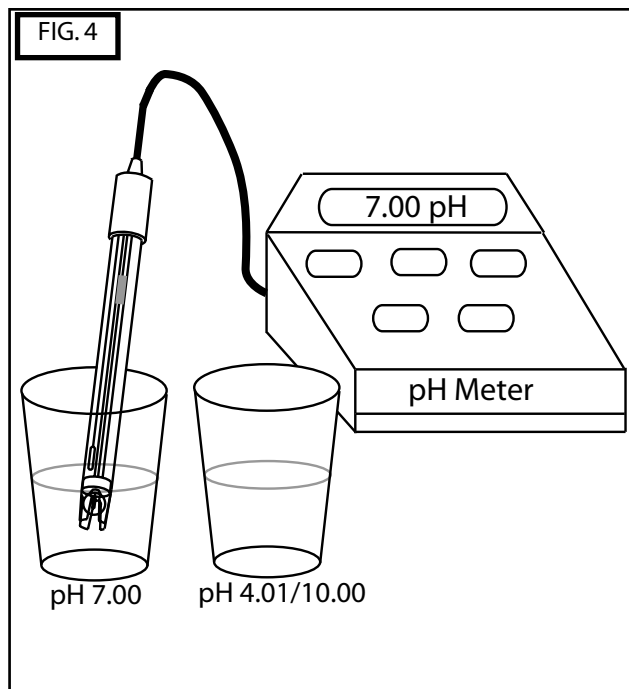
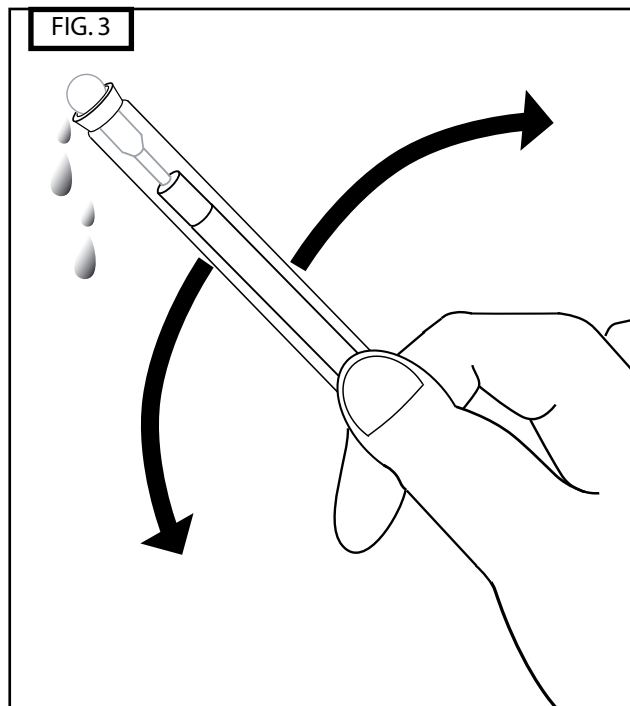

SECTION 3.0 ELECTRODE STORAGE

When pH readings are made infrequently, for example, several days or weeks apart, the electrode can be stored simply by replacing it in its soaker bottle. First, slide the cap onto the electrode, then the o-ring, then insert the electrode into the bottle and firmly tighten the cap. If the solution in the soaker bottle is missing, fill the bottle with pH 4 buffer.

SECTION 4.0 ELECTRODE CLEANING

Coating of the pH bulb can lead to erroneous readings including shortened span (slope). The type of coating will determine the cleaning technique. Soft coatings can be removed by vigorous stirring or by the use of a squirt bottle. Organic chemical or hard coatings should be chemically removed. 5-10% hydrochloric acid (HCl) soak for a few minutes often removes many coatings. If cleaning does not restore performance, reconditioning may be tried. **DO NOT USE BRUSH OR ABRASIVES ON ELECTRODE (SEE FIG 5.)**

SECTION 5.0 REFILLING REFERENCE SOLUTION

Electrodes with shifted readings but acceptable span may have contamination of the reference electrolyte solution. To refill the reference electrolyte (REFER TO FIG 6):

- 1) Rotate ball-valve to open position
- 2) Press the spring loaded top and hold until as much liquid as possible leaks out of the junction near the pH glass.
- 3) Release the spring loaded top cap and refill the solution through the ball-valve until it reaches about ½" below the refill hole. A 4oz. bottle of refill solution (part number S20) is included with each electrode.
- 4) Please note also that the refill solution should not be allowed to drop 2.5" below the valve hole. If this occurs, add more solution until it reaches ½" under the refill hole of the ball-valve. Please use refill solution S20 or 3.5M KCl solution only. No other solutions should be used!

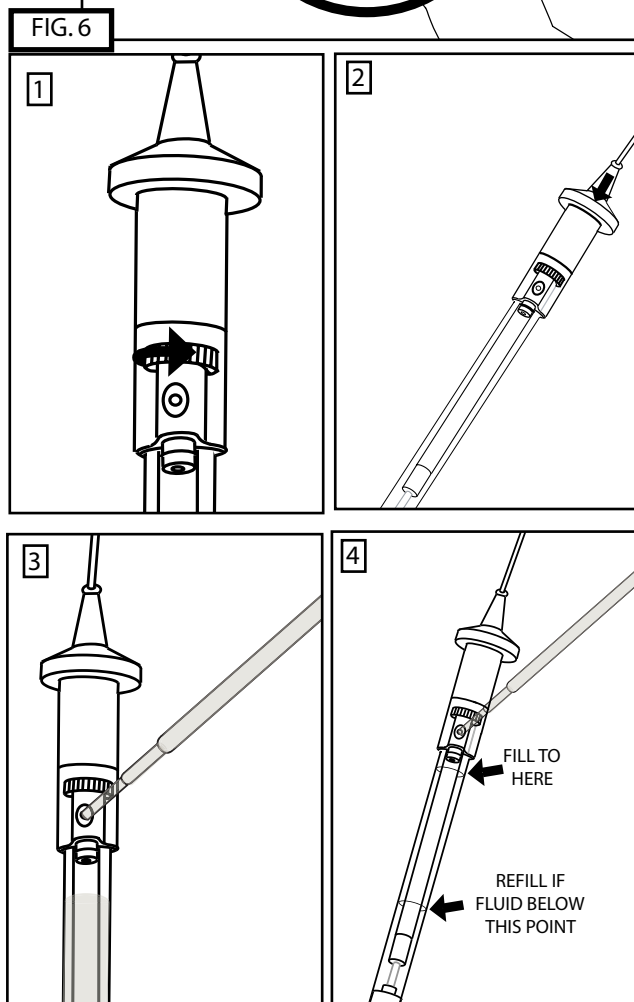
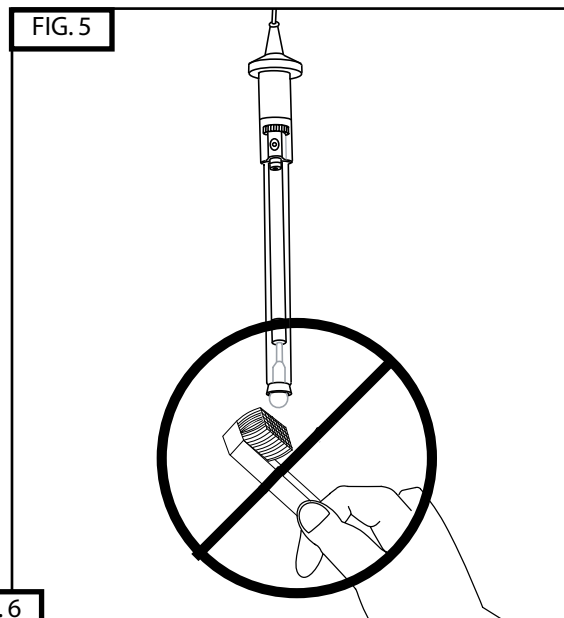

SECTION 6.0 ELECTRODE RECONDITIONING

When reconditioning is required due to electrode aging see Helpful Operating Techniques, item 9), the following chemical treatments can be tried. They are presented in the order of the severity of attack on the pH glass and may not improve (and in some cases actually further deteriorate) electrode performance.

NOTE: Use proper precautions when handling these hazardous chemicals. Ammonium bifluoride and HF (hydrofluoric acid) are extremely hazardous and should only be used by qualified personnel.

1. Immerse the electrode tip in 0.1 N HCl for 15 seconds, rinse in tap water and then immerse tip in 0.1 M NaOH for 15 seconds and rinse in tap water. Repeat this sequence three times and then recheck the electrode's performance. If performance has not been restored, try Step 2.
2. Immerse the tip in a 20% solution of NH_4F -HF (ammonium bifluoride) for 2 to 3 minutes, rinse in tap water and recheck performance. If performance has not been restored try Step 3.
3. Immerse electrode tip in 5% HF for 10-15 seconds.
4. Rinse well in tap water, quickly rinse in 5N HCl, rinse well in tap water and recheck performance. If performance has not been restored, it is time to get another Sensorex epoxy body combination pH electrode. (SEE FIG. 7)

