

INTRODUCTION

Thank you for purchasing a Sensorex TCSP PEEK Toroidal Conductivity Sensor (FIG. 1). The Sensorex TCSP toroidal (inductive) conductivity sensors feature a wide measurement range and dependable toroidal technology over the range 0-2000 $\mu\text{S}/\text{cm}$. Resistant to corrosion, coatings and fouling common to contacting conductivity sensors, the TCSP3020 and TCSP3021 are designed for a trouble-free and long service life.

PEEK (unfilled, polyetheretherketone) is the standard material of construction and has a wide solvent tolerance and temperature stability to 130 degrees C. The TCSP Models features a 3/4" MNPT for submersion installation. A PT1000 RTD temperature element is built into the sensor for temperature compensation.

All TCSP sensor models are available with 10ft or 20ft long 9-conductor cable. Custom lengths are available. Choose from models for use with our EX2000RS, TCSMA, or TCSTX transmitters or for use with our SSRE remote electronics for conversion to MODBUS output.



FIG. 1

SPECIFICATIONS

Measuring Range:	0-2,000,000 $\mu\text{S}/\text{cm}$
Body Material:	PEEK
Max Temperature:	170°C
Max Pressure:	295 psig
Temperature Compensation:	PT1000 RTD
Cable Length:	9 conductor (6 conductor plus shields); available in standard 10ft or 20ft lengths; custom lengths available on request
Process Connection:	3/4" MNPT

INSTALLATION

Your toroidal sensor can be installed in two ways:

1. Submersion Mount:

Mount sensor into rigid or flexible conduit, using a 3/4" NPT coupling and attaching to the 3/4" NPT threads near the sensor's cable. Be sure to seal conduit to avoid fluid build-up in conduit.

2. In-Line Mount:

The TCSP sensor can be installed in a Tee fitting through use of a bushing. Sensorex offers a Tee and Bushing in 304 Stainless Steel to provide good performance at high temperatures and in harsh chemical environments.

- Plumb Flow Cell FC900T into line. The 2" NPT fitting ensures the sensor head is in the sample stream.
- Install your TCSP sensor into the 3/4" NPT(F) opening of the FC900B Bushing.
- Install Sensor/Busing assembly into the Tee fitting. See FIG. 3. Align dot on sensor with inlet or outlet of the flow cell FC900T.

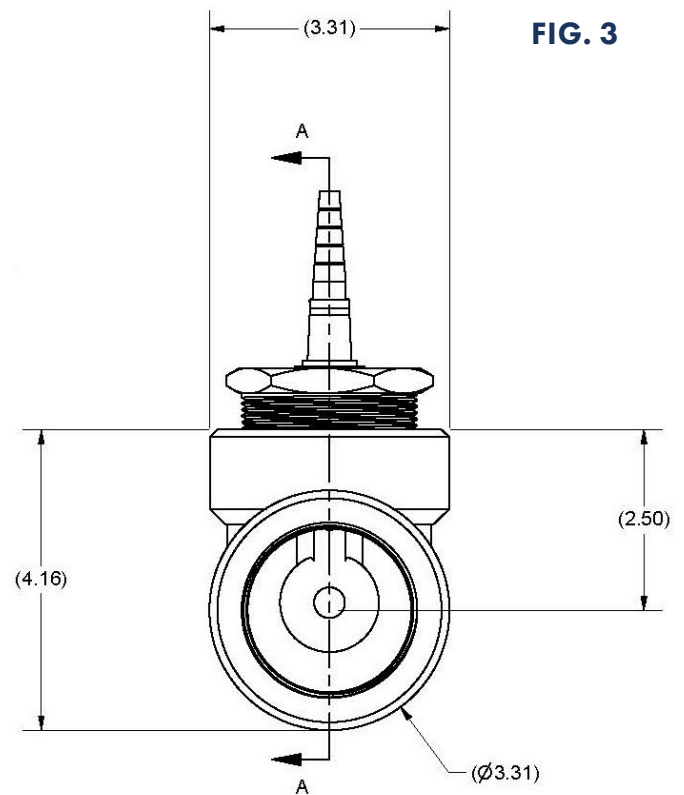
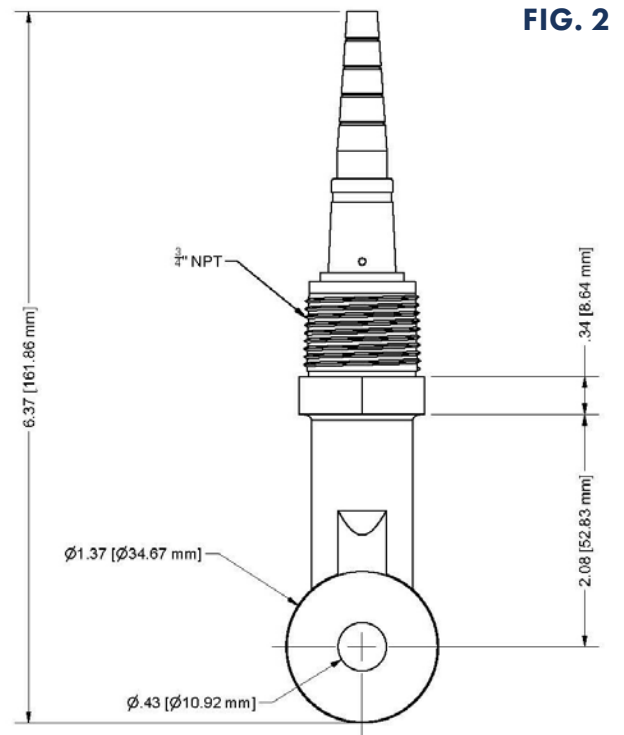

DESIGNED IN CALIFORNIA, USA
ASSEMBLED IN CALIFORNIA AND CZECH REPUBLIC

11751 MARKON DRIVE • GARDEN GROVE, CA 92841 • 714.895.4344 • WWW.SENSOREX.COM

© Sensorex Corporation. All rights reserved. In the interest of improving and updating its equipment, Sensorex reserves the right to alter specifications to equipment at any time.

WIRING

The probe has nine total leads. See FIG 4. The driver toroid is connected to the red and black leads, with the red shrink tubing around them. When using the probe with various controllers, it is important that the red lead be connected to an AC DRIVER or VOLTAGE IN position while the black lead is connected to a GROUND or DRIVER RETURN line.

The detector toroid is connected to the white and black leads, with the white shrink tubing around them. The white lead is typically connected to the SIGNAL IN location, and the black lead is connected to a GROUND or SIGNAL RETURN line.

The temperature element is connected to the green and black leads, with the green shrink tubing around them.

Connect these to the TEMPERATURE INPUT locations. The polarity is not important. The three bare leads - which supply individual pair shielding throughout the cable - should typically be connected to a ground or drain line. Note: The shield leads are not connected to one another; they are all individual shields for the three bundles of wires.

Refer to your controller manual for specific wiring details.

CABLE CONSIDERATIONS

Do not run cable in the same conduit with any other A.C. power wiring.

Do not route the cable close to any high-current demanding equipment. Seal conduit to avoid build-up of moisture.

Do not cut the cable.

If needed, shorter or longer cables can be provided.

FIG. 4

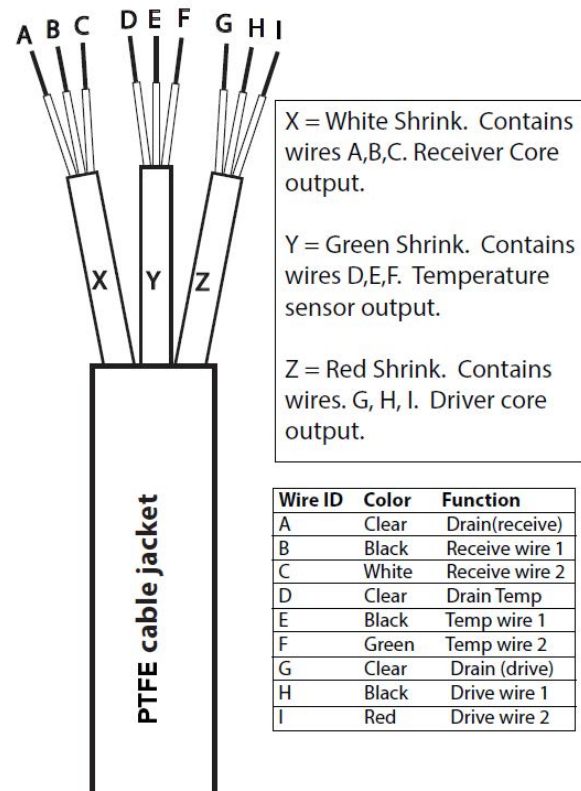

CALIBRATION

Calibration of the sensor must be done after installation and wiring. Use a "low" and a "high" known calibration standard solution. The "low" solution is often DI water or air, and is used to calibrate the zero point of the controller. Plotting these two points will create a straight line, which can be used to find the conductivity value of any solution in the range.

Make sure probe is immersed in the calibration fluid with the toroids totally submerged.

If the sensor is to be used in a submersion application, calibrate the sensor in a large glass or plastic beaker with all sides of the sensor at least one inch away from the wall. See FIG 5. If the production installation is a pipe (plastic or metal), calibration should be performed in a similar pipe arrangement. All electrodeless (toroidal) sensors have a wall effect that must be taken into account during calibration.

If the non-conductive (plastic) wall is within one (1) inch of the sensor, the sensor's reading will be reduced due to the insulator interaction with the current path. If the sensor is within one (1) inch of a conductive (metal) wall, the sensor's reading will be increased due to the shorting effect of the conducting wall. These wall effects can be calibrated out of the system by simulating the application's mounting configuration. A plot showing the effects of insulating and conducting walls on the output can be seen in FIG 6.

During calibration and production installation (especially in a submersion environment), it is important to dislodge any air bubbles and pay special attention to the center hole of the toroids. Ensure that toroids are totally covered with fluid when calibrating. See FIG 5.

Please refer to your controller's manual for specific calibration instructions.

MAINTENANCE

The major advantage of the Electrodeless (Toroidal) Sensor is its ability to operate with minimal maintenance. The only maintenance actions required during the normal operational life of the sensor are those aimed at preventing the toroidal opening from being plugged with debris. Use a soft brush or rag to remove any debris in the core opening. If that does not work, try a mild detergent or weak acid (5 - 10% HCl).

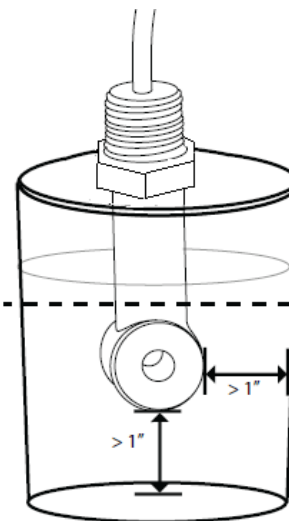
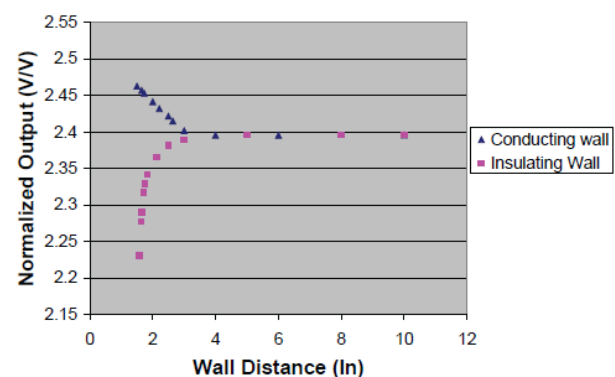

FIG. 5

Liquid must totally cover toroids (be above this line)

FIG. 6

Plot of Normalized Output as a Function of Probe Distance from Wall



TROUBLESHOOTING

If your sensor is not reading as expected, check resistance of lead. See FIG 7.

FIG. 7

SHRINK COLOR	WIRE COLOR	RESISTANCE
RED	RED	0.5 OHMS
RED	BLACK	
RED	CLEAR	
WHITE	WHITE	0.5 OHMS
WHITE	BLACK	
WHITE	CLEAR	
GREEN	GREEN	109 or 1090 OHMS**
GREEN	BLACK	
GREEN	CLEAR	